



GIU.RO.

... DI AVER VISTO UN ARTISTA

OBIETTIVO PROGETTO



OGGETTO DI DESIGN

A SCOPO LUDICO - DIDATTICO



SMATERIALIZZAZIONE DI
GIULIO ROMANO
E IL SUO CONTRIBUTO
PER LA CITTA' DI MANTOVA

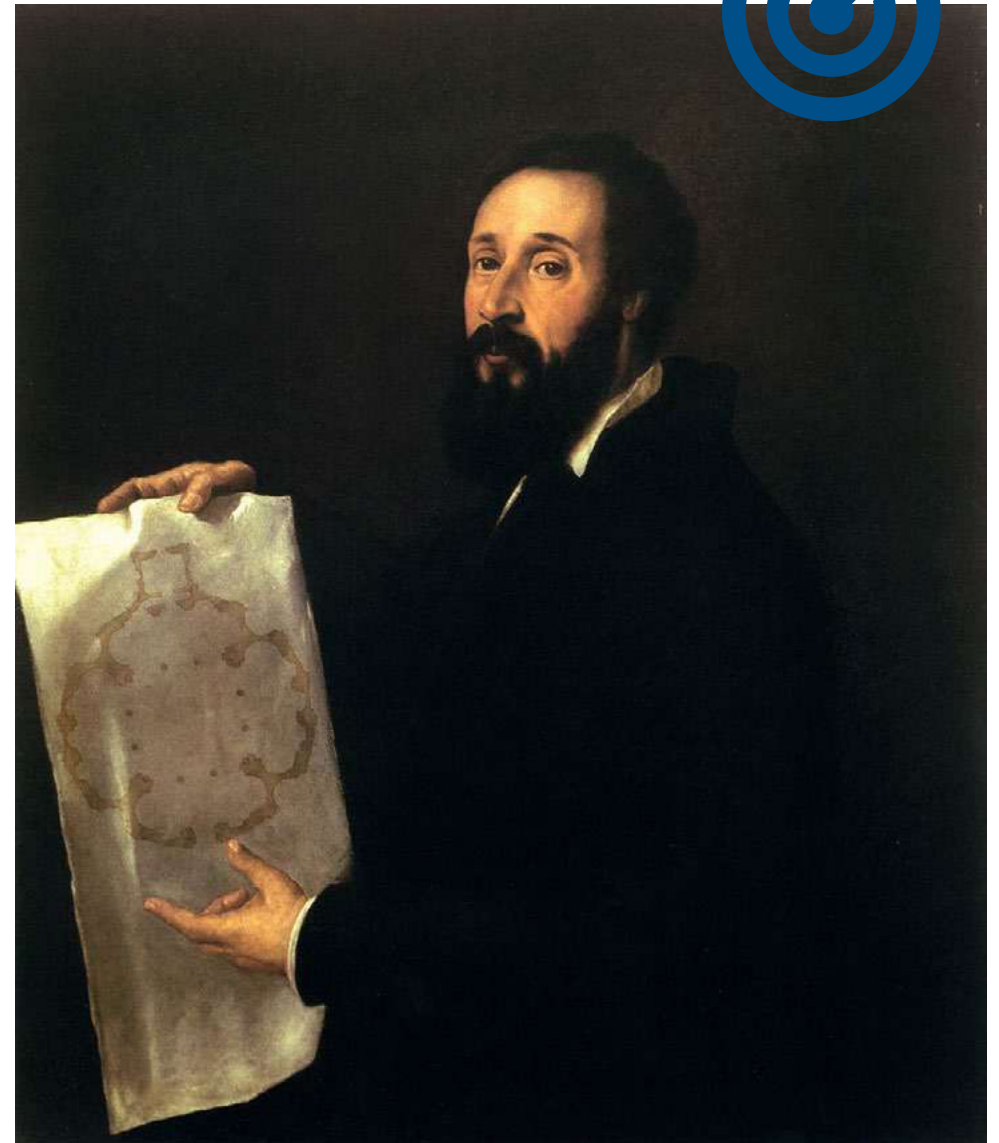

ISPIRAZIONE - RIFERIMENTO

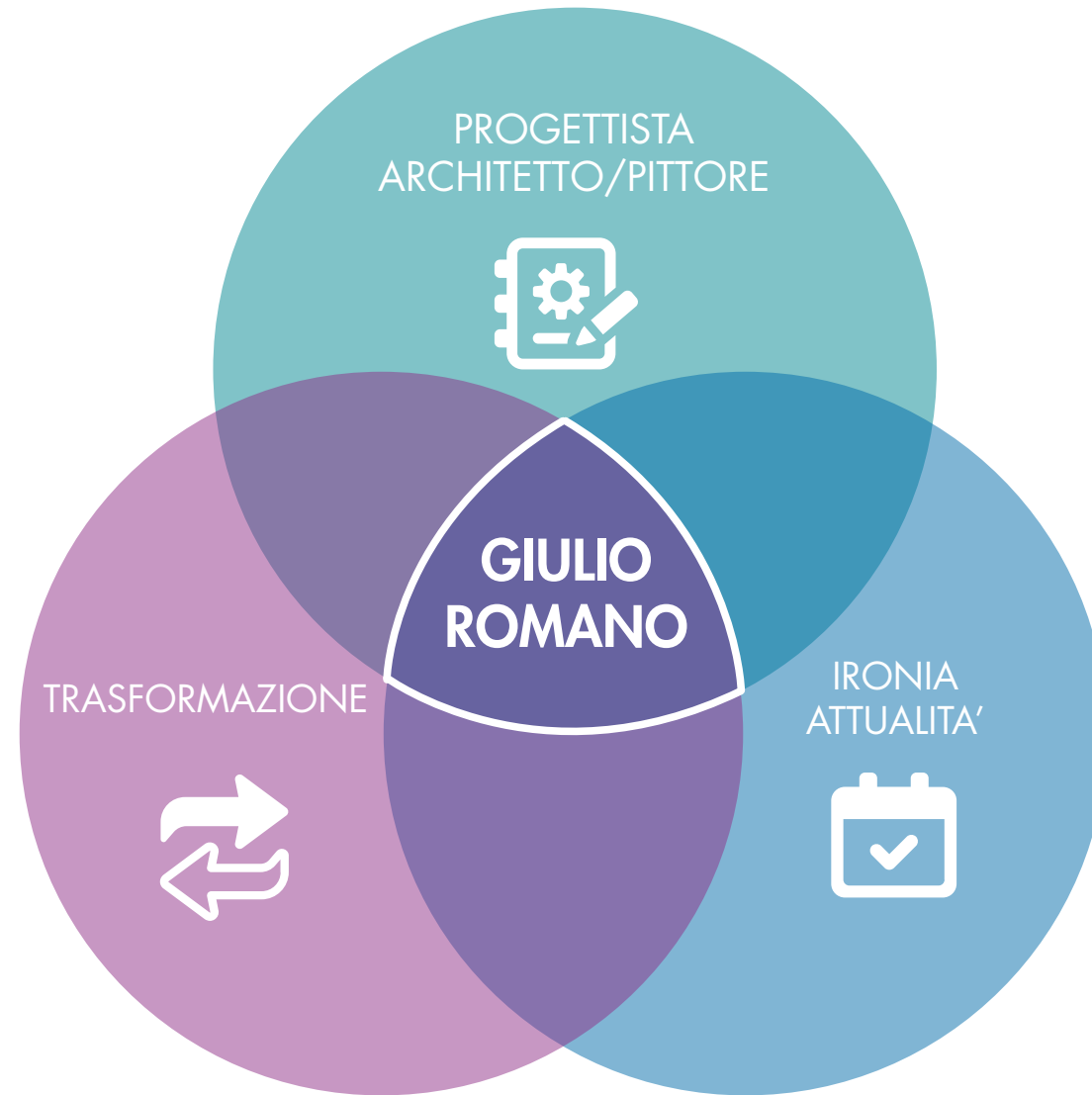

PROPOSTA ✓

COMPOSIZIONE/SCOMPOSIZIONE elementi ispirati alla sua ARTE

NUOVO / SEMPRE ATTUALE

METAMORFOSI



CAMPI DI INDAGINE

LIVELLO FORMALE

ARCHITETTURA



LIVELLO DECORATIVO

PITTURA



CAMPI DI INDAGINE

LIVELLO FORMALE

ARCHITETTURA



**EDIFICI REALIZZATI
NELLA CITTA'
DI MANTOVA**

LIVELLO DECORATIVO

PITTURA



**AFFRESCHI NELLE
SALE PRINCIPALI DI
PALAZZO TE**

PROGETTO



OGGETTO/INSTALLAZIONE
MODULARE TRAMITE INCASTRO

Componenti creati tramite le
silhouettes degli elementi che
caratterizzano l'architettura
di Giulio Romano

PIEDISTALLO - BASE STRUTTURA

Creata tramite l'innesto di due
elementi che raffigurano la
città di Mantova

VISTE PROSPETTICHE

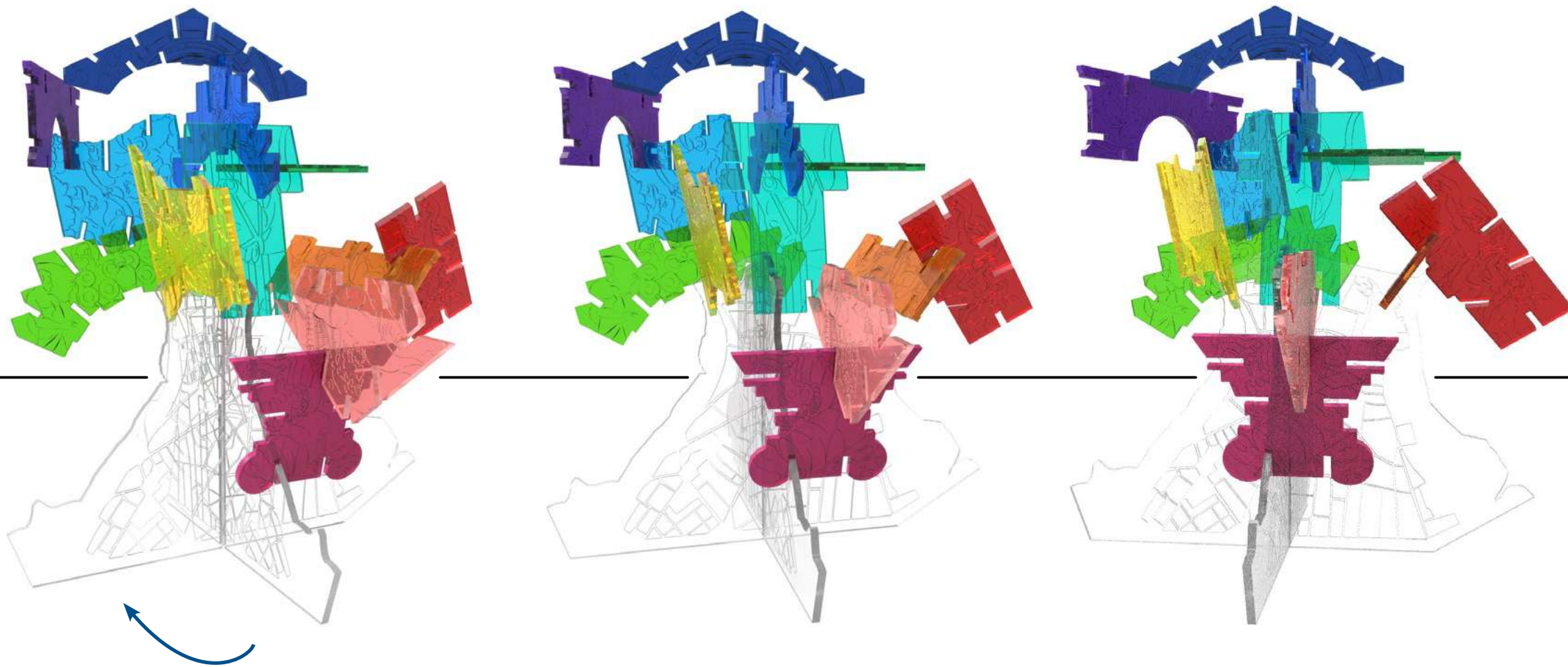

INFINITE POSSIBILITA' DI COMPOSIZIONE

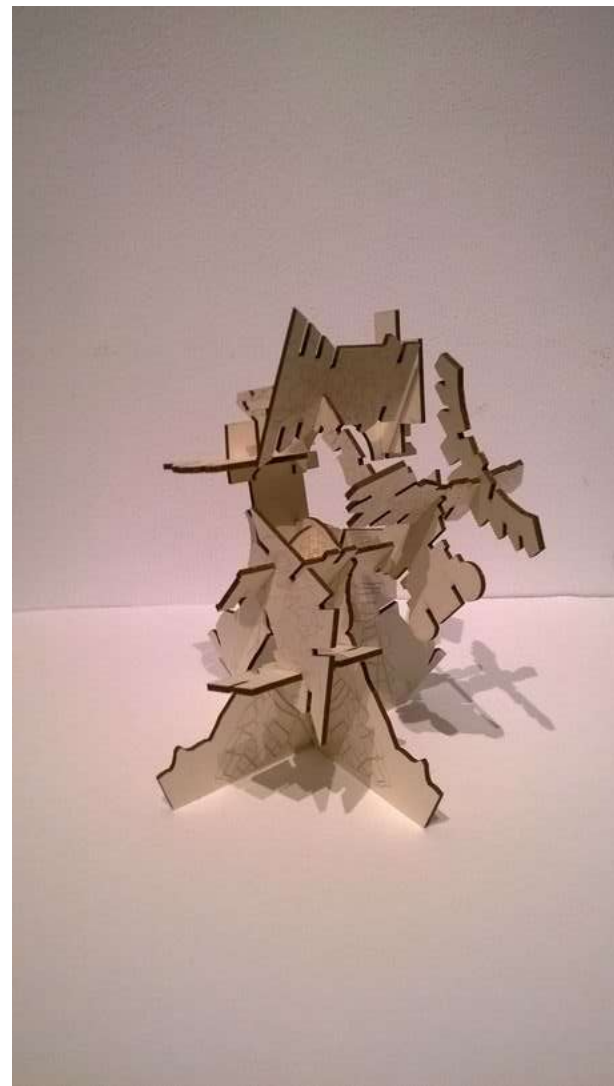
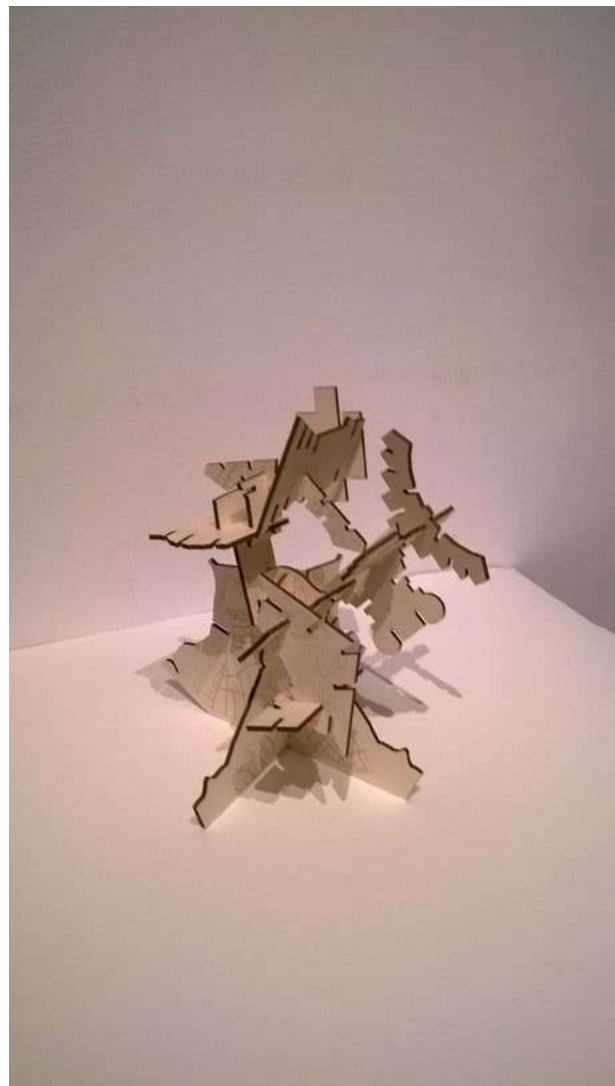
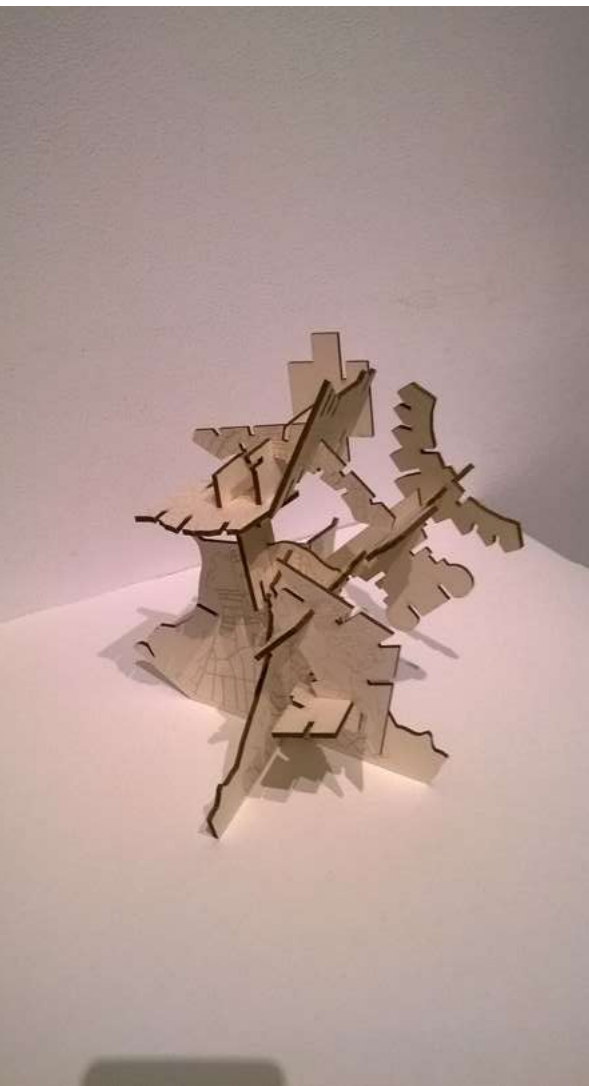

CARATTERISTICHE

POSSIBILITA' DI MODIFICA DELLA FORMA
TRAMITE L'INTERAZIONE CON IL PUBBLICO

L'ESPERIENZA CON L'OGGETTO PERMETTE
DI FRUIRE GIULIO ROMANO TRAMITE
LA PROPRIA

CREATIVITA'



FOCUS - COMPONENTI



Mantova: città FONDATA(le) per l'arte di Giulio Romano

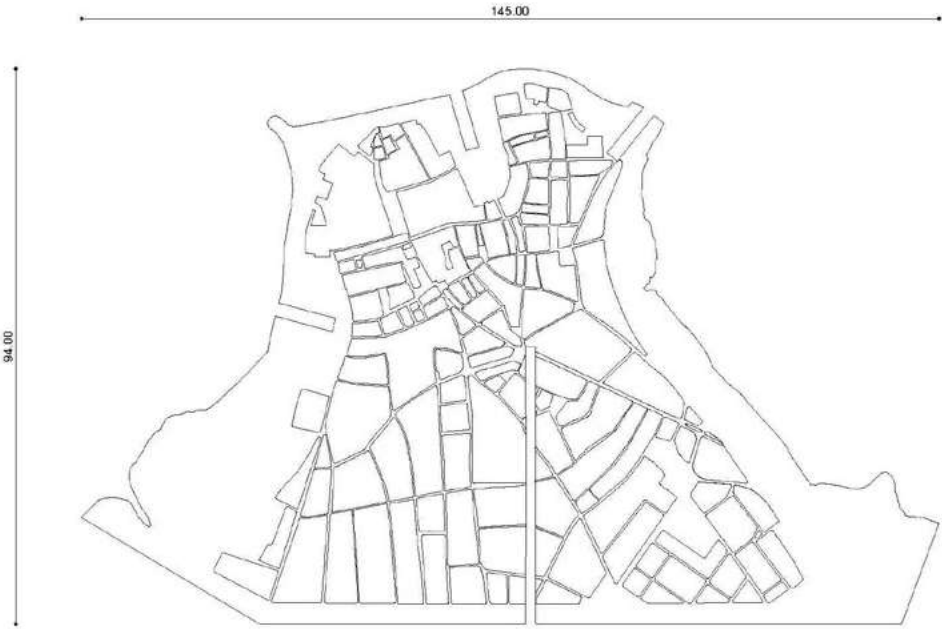
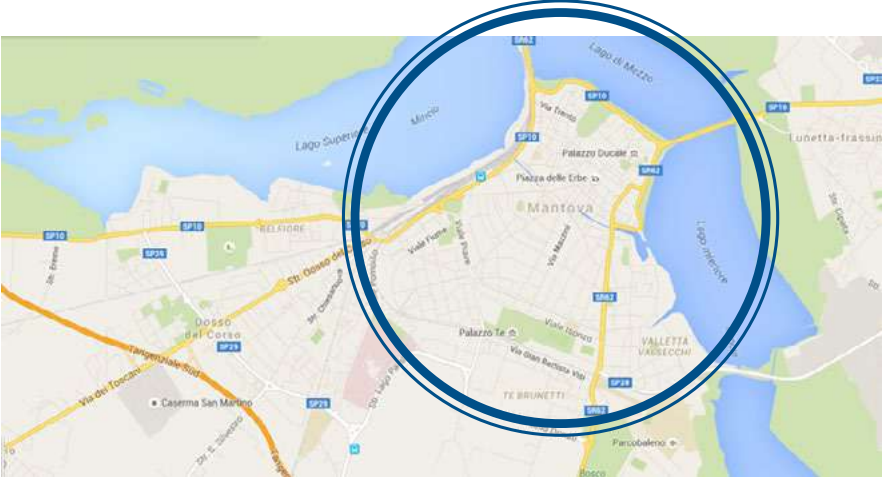

FOCUS - COMPONENTI

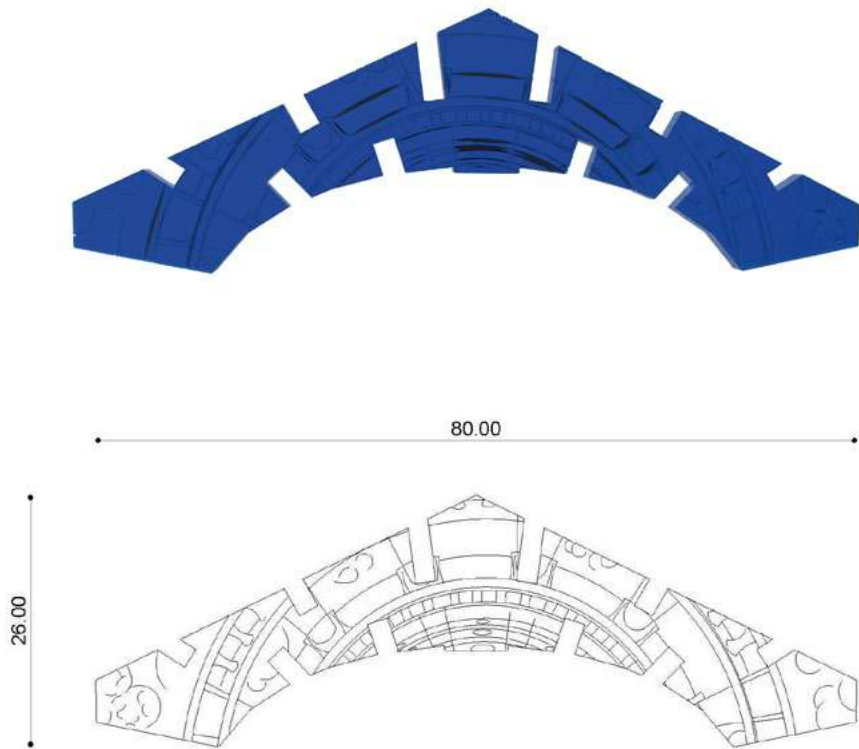

Elemento
Casa di Giulio Romano



Dettaglio
Sala dei Giganti

FOCUS - COMPONENTI

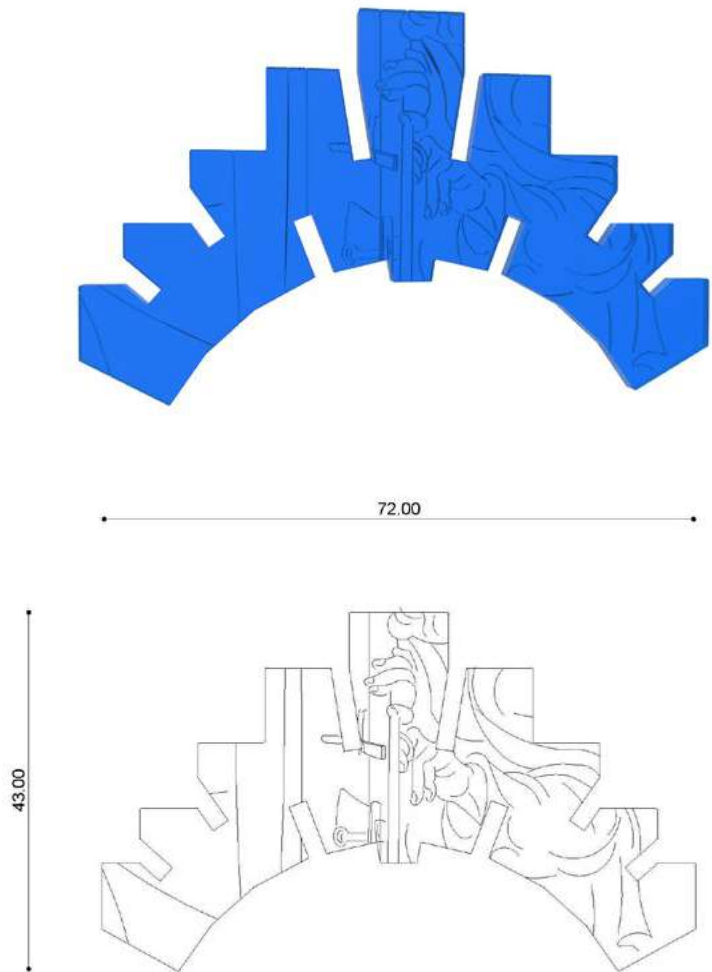

Elemento
Palazzo Te



Dettaglio
Due Amanti

FOCUS - COMPONENTI

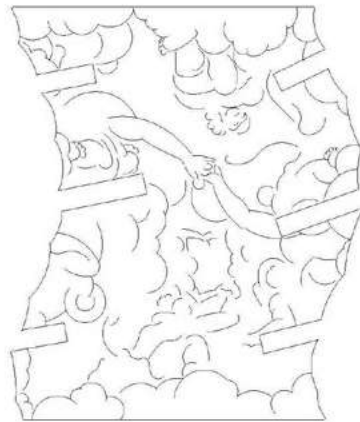
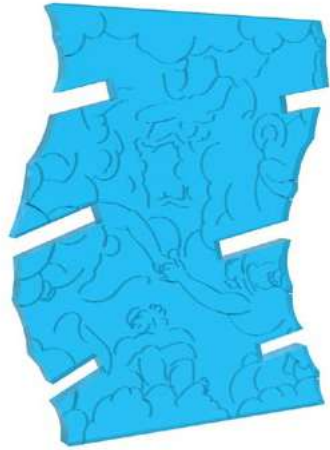

Elemento
Palazzo Ducale



Dettaglio
Sala di Amore e Psiche

FOCUS - COMPONENTI

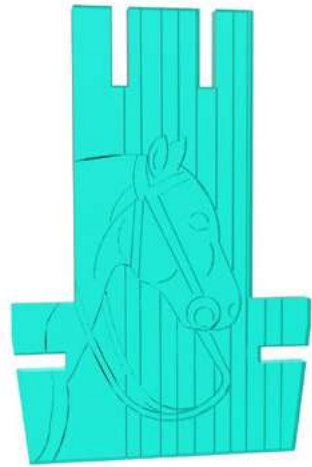

39.00

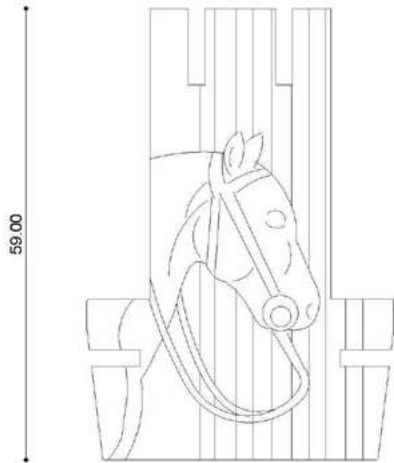

59.00



Elemento
Palazzo Te

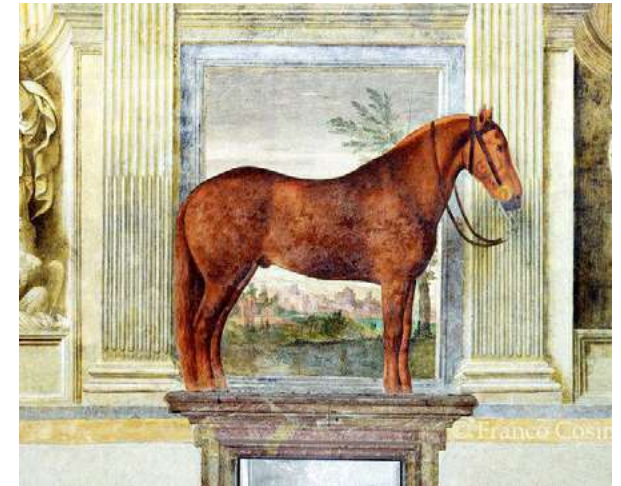

Dettaglio
Sala dei Cavalli

FOCUS - COMPONENTI

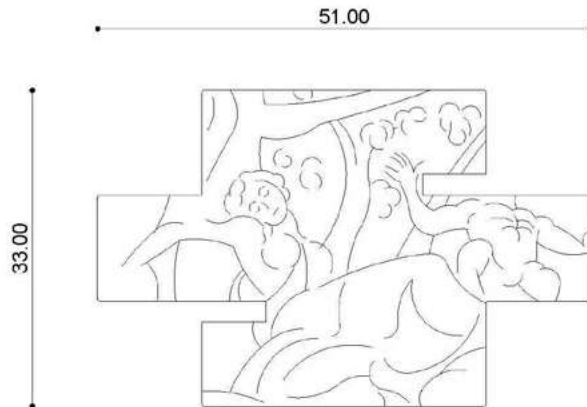
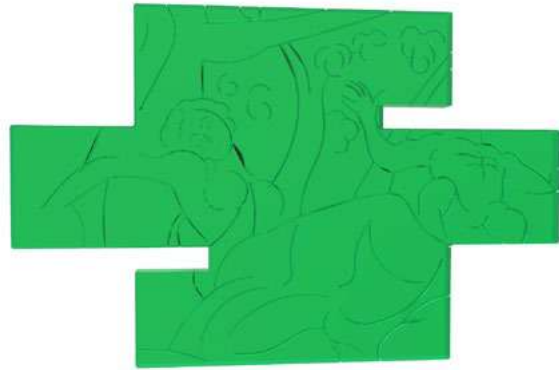

Elemento
Porta Giulia



Dettaglio
Sala di Amore e Psiche

FOCUS - COMPONENTI

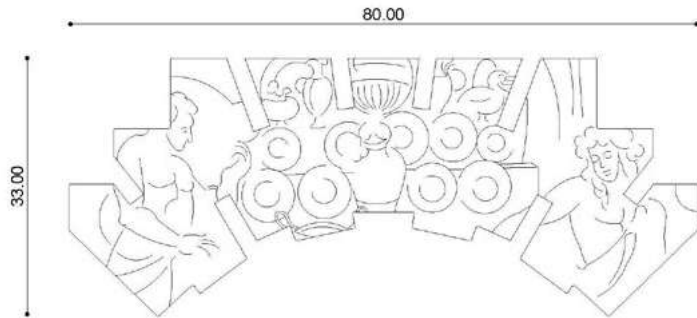

Elemento
Pescherie



Dettaglio
Sala di Amore e Psiche

FOCUS - COMPONENTI

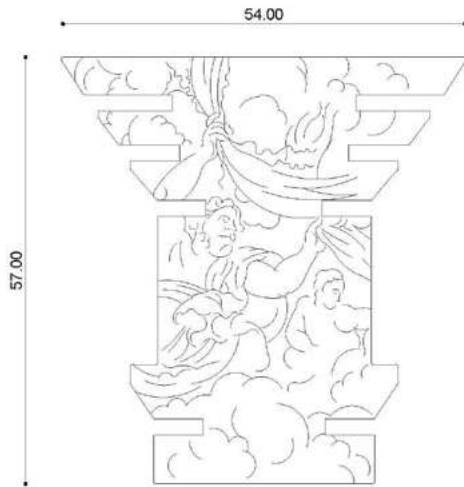

Elemento
Palazzo Capilupi



Dettaglio
Sala dei Giganti

FOCUS - COMPONENTI

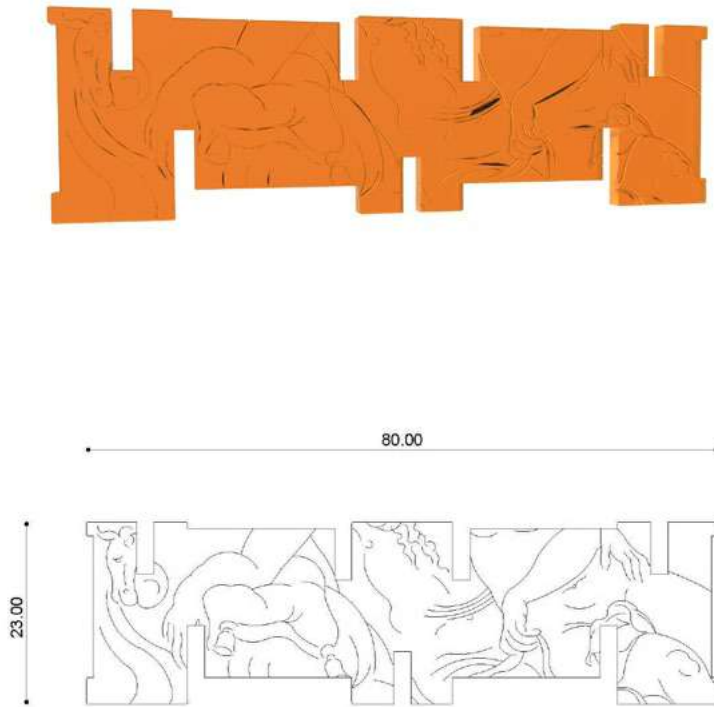

Elemento
Casa Tortelli



Dettaglio
Due Amanti

FOCUS - COMPONENTI

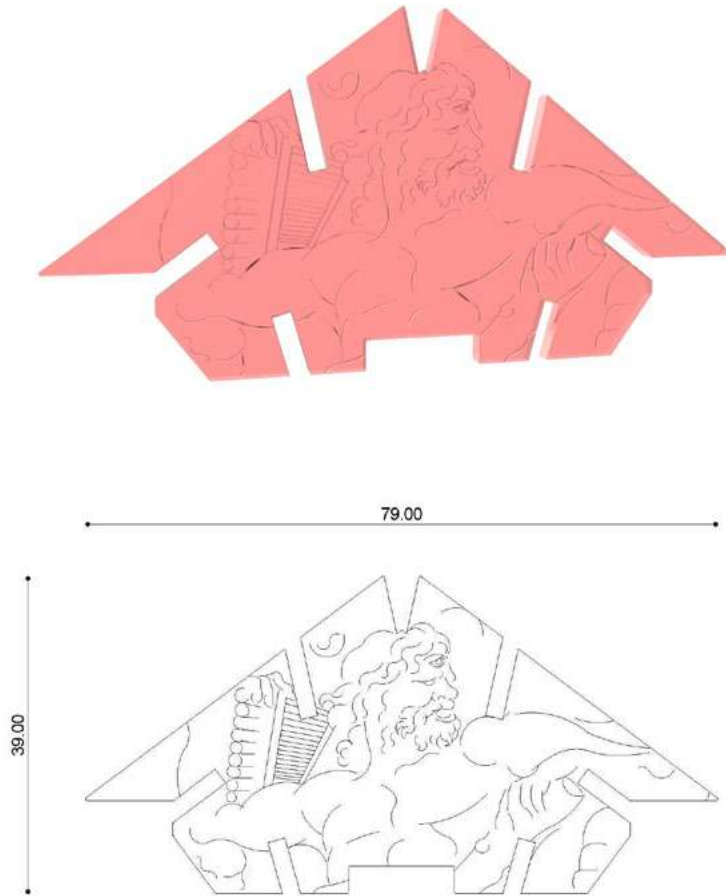

Elemento
Palazzo Te



Dettaglio
Sala di Amore e Psiche

FOCUS - COMPONENTI

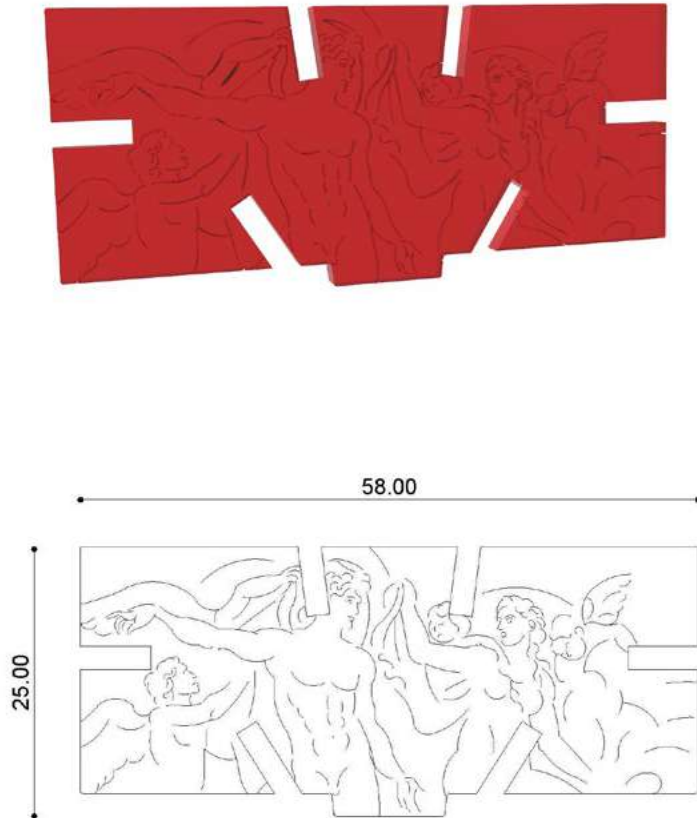

Elemento
Porta Giulia



Dettaglio
Sala di Amore e Psiche

FOCUS - COMPONENTI

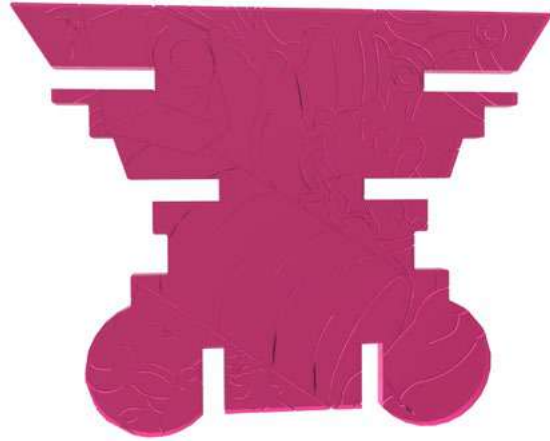

54.00



42.00



Elemento
Portale della Dogana



Dettaglio
Sala dei Giganti

FOCUS - COMPONENTI

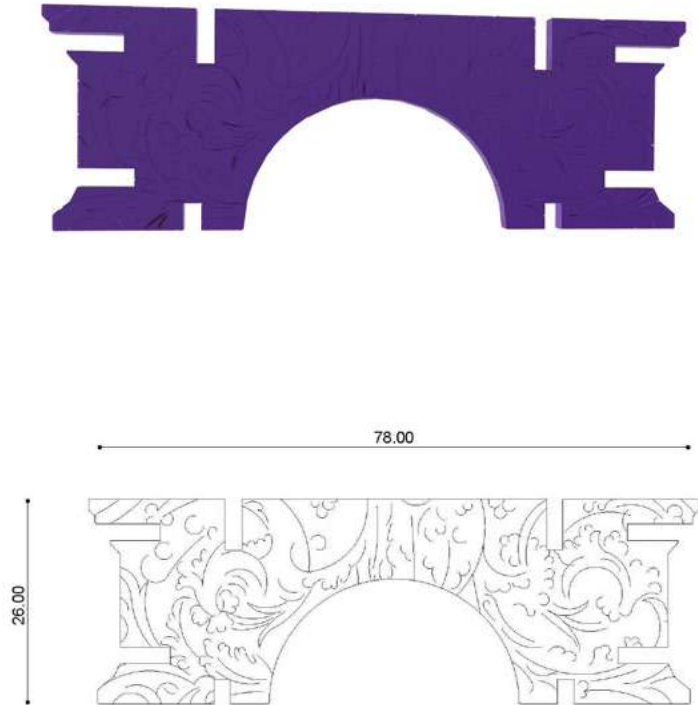

Elemento
Basilica S. Andrea



Dettaglio
Sala delle Imprese

SCOPRIRE GIULIO ROMANO - 1° livello

APPRENDERE L'ARTISTA TRAMITE ELEMENTI DI CITAZIONE
all'interno dell'oggetto



DIDATTICA / DIVERTIMENTO



TARGET AMPIO

PUBBLICO ATTRATTO DALLE CARATTERISTICHE DELL'OGGETTO

DIFFERENTI FRUIZIONI  DIFFERENTI ESPERIENZE

LA FORMA SI RIGENERA CONTINUAMENTE

SCOPRIRE GIULIO ROMANO - 2° livello

ELEMENTI - PUNTO DI PARTENZA

*PERCORSO ALLA SCOPERTA DI GIULIO ROMANO
IN GIRO PER MANTOVA

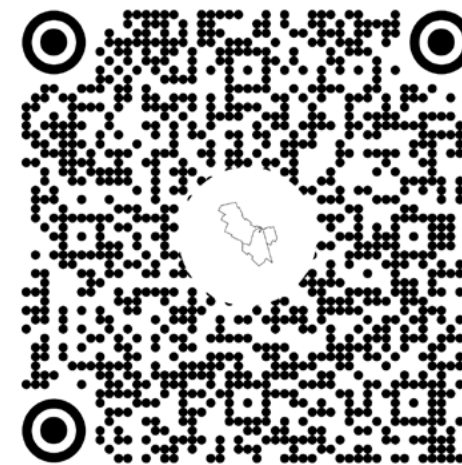

APPLICAZIONE

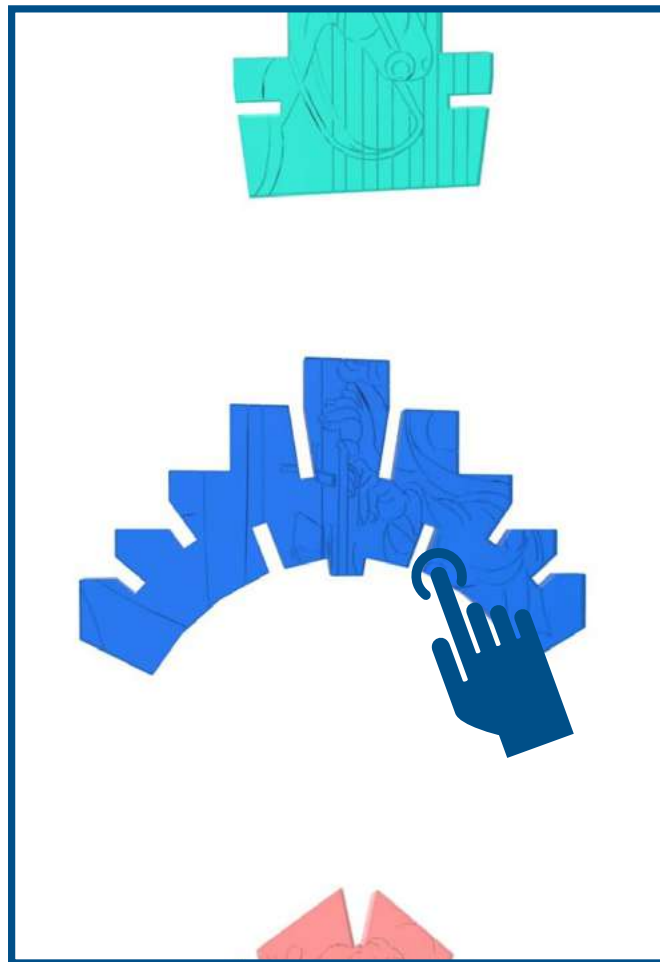

STIMOLO

PER ANDARE A SCOPRIRE IL CONTRIBUTO DELL'ARTISTA PER LA CITTA'



FRUIRE GIULIO ROMANO

EDIFICI MUSEALI



GADGET

ARTISTA NEL QUOTIDIANO



NUOVA FRUIZIONE

RIPRODUCIBILITA'

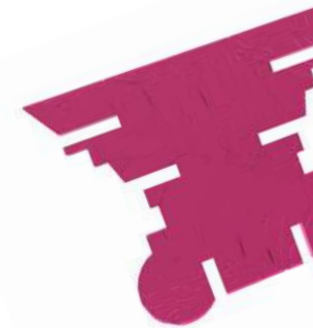
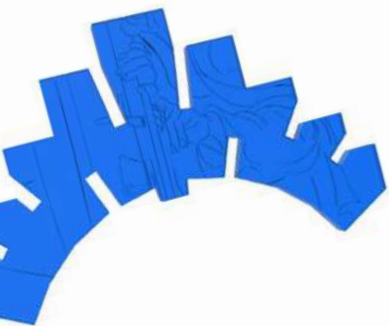
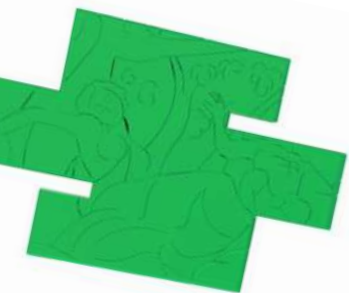

CONTESTUALIZZAZIONE





GRAZIE PER L'ATTENZIONE

Pantini Chiara - Raspa Vittorio - Sperandio Laura
